

THE  
GRYPHON





# THE GRYPHON



## **Gryphon Apex** **Stereo / Mono Power Amplifier**

### **Owner's Manual**

## Table of Contents

Introduction .....	5	Rear Panel, Apex Stereo .....	23
You Have Arrived .....	6	Rear Panel, Apex Mono .....	24
Creating an Icon .....	7	Green Bias.....	25
The Man behind the Brand .....	8	Features .....	26
The Gryphon Story .....	9	Specifications .....	27
Foundation for Excellence .....	10	Dimensions .....	28
Timeless Beauty .....	12	Error Indication and Trouble Shooting.....	29
Bespoke Manufacture .....	12	Internal Fuses .....	30
The Gryphon Apex .....	13	Warranty & Support .....	32
Placement .....	16	IMPORTANT SAFETY INSTRUCTIONS .	33
AC voltage .....	16	Notes .....	34
Care and Maintenance .....	16		
Choice of Cables .....	17		
Unpacking and Setup .....	18		
Installation .....	18		
Burn-in and Warm-up .....	18		
Mains Switches .....	18		
Apex Power Stereo and Mono Manual .....	19		
User Instructions .....	20		
Functions .....	22		



## The Gryphon Name

The Gryphon moniker and symbol is an appropriate image for the brand, inspired by Greek mythology, part eagle, part lion, the perfect union of grace and agility with power and authority.

Gryphon Audio Designs is quite simply

*“The ultimate choice for the enthusiast who wants the sound with no frills other than the luxury imparted by the fit, feel and finish.”*

(Hi-Fi News & Record Review magazine, UK)

## The Gryphon Genetic Code

The Gryphon DNA has been defined by one writer as:

*“A code of perfectionism, the likes of which I’ve only ever seen at the Bugatti atelier in Alsace or at the great watch houses in Switzerland. It is the result of not accepting the notion of compromise, on any level.”*

(Ken Kessler, audio critic)

At the very core of this genetic code lies what one critic described as Rasmussen’s

*“Subversion of traditional hi-fi styling”*

(HiFi Choice magazine, UK)

with designs *“...so clean and simple, yet elaborate.”*

(Positivefeedback.com, USA)

Similar sentiments echo around the world.

## You Have Arrived

### **Gryphon Presents the World's Finest Electronics**

For nearly four decades, Gryphon Audio Designs has defined the state-of-the-art in High End audio. In terms of aesthetics, circuit design and innovation, materials, build quality, intuitive control and, most importantly, audio performance, Gryphon products have set the standard by which all others are judged. With the introduction of the the Gryphon Commander Preamplifier and the Gryphon Apex Mono and Apex Stereo Power Amplifiers, Gryphon has once again pushed the audio art to a new and higher level.

In addition to detailing all operational and functional aspects of these incomparable components, this Owners' Manual describes the history and design ethos of Gryphon Audio Designs and our passionate pursuit of perfection. Please take a few moments to learn about the company in whose products you have invested.

Thank you for your patronage !



## Creating an Icon

In virtually every category of consumer goods - fashion, automobiles, furniture, wine, watches, etc. - there exists a revered top tier of luxury and excellence, a small yet celebrated, High End segment populated by innovative designers who pursue perfection with little concern for production economies, practicality or cost.

The essence of these “aspirational brands” is consistent: aesthetic beauty, advanced technologies, superior performance and extravagant build quality combine to achieve unsurpassed levels of fit, feel, finish and function. As a result, all of these offerings are the very best that they can possibly be, for the discerning few who can appreciate and afford them.

While many of these marques are familiar to luxury consumers, others are known only to a limited group of cognoscenti. Curiously, High End audio systems remain a mystery to many affluent connoisseurs. This lack of enthusiasm can be explained by products whose awkward functionality or poor cosmetics clash with the refined aesthetic sensibilities of potential owners.

As for aesthetics, the sculptural beauty of Gryphon components, combined with their extraordinary fit and finish, elevates fine audio componentry to objects of worship at home in the finest domestic spaces.

For the uninitiated, who mistakenly assume that they are unable to distinguish finer musical nuances as reproduced by High End audio systems, even the briefest audition proves that most individuals can discern and appreciate the “you-are-there” realism offered by fine High End home entertainment equipment. Rest assured: if you’re passionate about music, the illusion that the listener can be transported to the performance venue is addictive.

The fortunate few with the means to acquire the ultimate in-home entertainment owe it to themselves to experience the life-changing difference which a Gryphon audio system delivers.



## The Man behind the Brand

After 33 years at Gryphon Audio Designs, Flemming Erik Rasmussen retired from the company he founded in 1985 to devote himself to his favourite pastimes including his first love, painting.

Rasmussen's audio career was purely serendipitous. After earning a degree in painting and graphic arts at Denmark's Aarhus Art Academy, he taught painting and photography before becoming chief designer of textiles and imprints for Scandinavia's largest sportswear company, then resigned to form 2R Marketing, which quickly became Denmark's leading High End audio distributor, later founding Gryphon as an offshoot of that company.

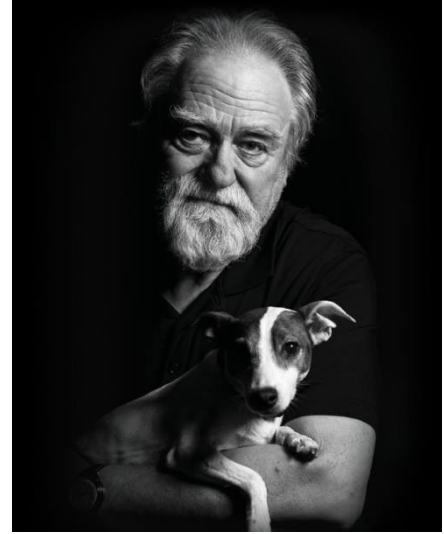

*The legendary Gryphon Head Amp*

The first product, the now legendary Gryphon Head Amp, was developed for Flemming's personal use; however, demand generated by rave reviews and "audiophile buzz" led to the formal establishment of Gryphon Audio Designs as a separate corporate entity.

Following the immediate success of the Gryphon brand, distribution was phased out in 1993 so that Rasmussen could dedicate his efforts entirely to Gryphon.

Rasmussen's background in fine arts and industrial design infused every Gryphon product with distinctive, luxuriant styling. His elegant, uniquely Scandinavian black-on-black designs were the original "Nordic Noir," long before TV crime dramas appropriated the term. His legacy is palpable in the visual aesthetic of current Gryphon chassis, as well as the ethos of quality and performance embodied in all Gryphon products.



## The Gryphon Story: Our Legend Continues



The Gryphon story is lovingly documented in two volumes: *The Gryphon Unplugged: 25 Years of Gryphon Audio Designs* (2010) and *The Art of the Gryphon: Form and Function in a Spiritual Union* (2015), a sumptuous photo gallery of Rasmussen's designs.

The transfer of daily management in connection with Flemming E. Rasmussen's departure left no uncertainty regarding the future direction of the Danish icon that continues to earn praise and admiration among connoisseurs worldwide.

Gryphon's talented team of engineers - lead by head of R&D: Mr. Tom Møller - who has made all electronic design for more than two decades - as well as other craftsmen and support staff remains wholly intact at all levels and every member continues to fulfill the brand's promise to offer the world's most inventive, technically advanced and aesthetically satisfying musical instruments to Gryphon's audience of passionate music lovers.

The engineering, artistic and marketing resources remain firmly committed to the principles that have defined the company from the very beginning.

Gryphon Audio Designs proudly affirms our unwavering passion for ultra-luxe audio in the service of music...and your listening pleasure.

## Foundation for Excellence: Gryphon Design Fundamentals

Thanks to state-of-the-art technical equipment and some of the finest minds in audio engineering, the Gryphon brand continues to define the highest standards of subjective and technical excellence. Common to all Gryphon components, these design fundamentals have proven essential for achieving ultimate performance:

Utilized in every Gryphon product, our **dual mono configuration** eliminates any possibility of crosstalk or other inter-channel interference and provides infinite channel separation which augments the ability to create space, focus, depth and transparency.

Because the electrical power in your home can fluctuate wildly in terms of voltage, noise and distortion, Gryphon incorporates **heavily regulated multi-stage power supplies** that act as effective mains conditioning filters. Displays and control circuits are fed by separate power supplies to isolate any digital noise artifacts and effectively prevents them from contaminating the analog signal path.

While the printed circuit boards in most audio products utilize conductor traces a mere 35  $\mu\text{m}$  thick, Gryphon employs **70  $\mu\text{m}$  or thicker PCB traces** of the highest purity copper. (The conductor traces used for all high current circuits in the Gryphon Apex Power Amplifiers are an astounding 105  $\mu\text{m}$  thick!)

Beginning with our very first product, "The Head Amp," all Gryphon products have featured extremely **wide frequency bandwidth**, because the ability to accurately reproduce infra-sonic and ultra-sonic frequencies ensures linear phase across the audible frequency range, for superior spatial performance. The implementation of circuits with wideband frequency response is a painstaking endeavour in which physical component layout and grounding pattern of the circuit boards are crucial to the attainment of superior sonic performance with no loss of inherent stability. Wideband frequency response ensures high slew rate - essential to the realistic recreation of the ultra-fast transients which routinely occur in live music - and is crucial in recreating the harmonic envelope of acoustic instruments.

All Gryphon designs are realized with none or an absolute minimum of negative global feedback which, when present in large amounts, can actually increase transient intermodulation distortion. With the exception of the Antileon series of power amplifiers (which utilize a minimum amount of negative global feedback) all Gryphon amplifiers are designed with **zero negative global feedback**.

Gryphon's research into the detrimental effects of magnetically induced distorted (MID) has led to the **elimination of magnetizable materials** wherever possible. To eliminate the effects of stray magnetic fields, non-magnetic materials are employed throughout every Gryphon product, with the unavoidable exception of the transformer shield box.



The mechanical design and assembly methods of the enclosure are carefully calculated to ensure **minimal chassis resonance**, either through the use of high mass mechanical grounding or decoupling. Vibration-sensitive components, capacitors in particular, are thus guaranteed a non-resonant environment which, in turn, provides a solid foundation for optimal electrical performance.

Gryphon's **artistically wrought, massive chassis** offers a vibration-proof environment for the sensitive electronics inside and provides crucial shielding from a polluted world of low- and high-frequency radio waves, power-line radiation and other electrical interference. Our obsessive attention to such issues enables the relaxing, open and transparent Gryphon sound.

Unique, non-intrusive protection circuitry offers reliable, fuss-free protection without compromising signal purity and signal path simplicity.

In the interest of ultimate fidelity and signal purity, tone controls and other **superfluous circuitry have been banished** from the signal path. The ground path has been carefully laid out in order to achieve superior sonic performance with no loss of stability. Component layout is designed to ensure the shortest conceivable signal path.

Exhaustive investigation precedes the selection of every component part and many **bespoke, proprietary components** are custom-built exclusively for Gryphon. And because what is left out is just as important as what goes in, an absolute **minimum of internal wiring** is included.

By lavishing attention on each aspect of the circuit and fully understanding the purpose and behaviour of every single part of the whole, our designers can optimize performance in each section before moving on to the next step. This ensures simplicity, a short signal path and a unity of purpose towards a single, well-defined goal: musical purity.

## Timeless Beauty, Aesthetic Perfection



*Home of the Gryphon is located in beautiful surroundings in Ry, Denmark*

The art of ultra-luxe audio systems should be apparent *before* the equipment is turned-on; for this reason, Gryphon products have always offered exquisite styling and superb user-friendliness to complement their stunning audio performance. In every Gryphon product, form follows function in a unique synthesis of aesthetics and operational simplicity which arises organically from the audio circuit design. Gryphon components embody sophisticated technology and cutting-edge industrial finish executed with the best of artisanal handcraftsmanship, all in the service of music. The peerless finish, build quality, ergonomics and pride of ownership that contribute to the wholistic Gryphon concept can only be fully understood and appreciated through personal experience with our products.

## Bespoke Manufacture for Heirloom Build Quality



At our laboratories and manufacturing facilities in Denmark, we maintain full control over every aspect of development and production, and our team members follow each Gryphon component from initial concept to early prototype and through to final quality control. Printed circuit boards are assembled by a supplier of precision military and medical equipment employing the highest standards of quality control and pre-inspection of components. Chassis parts are manufactured by specialists chosen solely for their outstanding quality of workmanship. In every aspect of every Gryphon product, the same stringent standards of excellence apply. Each unit is individually tested and then, after a 48-hour burn-in sequence, each product again undergoes both electronic and audio performance testing, ensuring generations of flawless performance.



## The Gryphon Apex

### Gryphon Apex: The Pinnacle of Performance

It has always been Gryphon's mission to achieve the highest possible audio performance. In terms of sheer musicality, transparency and realism. With the Gryphon Apex Mono and Apex Stereo Power Amplifiers, Gryphon Audio Designs elevates pure Class A power amplification a titanic leap above what was previously considered possible. The Gryphon Apex takes us several crucial steps closer in the never-ending quest for a more natural and convincing musical illusion.

Years of experience developing the Antileon EVO and Mephisto power amplifiers, as well as ongoing research in the fields of circuit topology, component quality and reliability have culminated in the Gryphon Apex: the new flagship amplifier of the Gryphon Audio Designs brand.

The material specifications of the Gryphon Apex illustrate its cost-no-object design: The Gryphon Apex Mono features a staggering complement of 128 very high-current bipolar output transistors (64 per chassis), 2,080,000  $\mu\text{F}$  (>2 Farad) capacitor banks (>1 Farad per chassis), four separate custom-made 2,000 VA toroidal transformers (two per chassis), all housed in a magnificently crafted, constrained-layer-damped chassis. The Gryphon Apex Stereo tips the scales at 202kg (nearly 450 pounds), while a pair of Apex Mono weigh-in at 404kg (900 pounds)!

Given the massive power reserves available at all times, Gryphon Apex amplifiers simply do not "see" the loudspeaker; in other words, Apex' virtually limitless reservoir of power and current renders it immune to loudspeaker characteristics. No speaker load, no matter how reactive, can affect Apex' performance. This means that Apex always delivers its ultimate sound quality, regardless of loudspeaker choice. What's more, unlike other high-power amplifiers, Gryphon's no-compromise, pure Class A topology offers this prodigious power combined with ultimate refinement and delicacy in musical presentation.

It is Gryphon's fundamental philosophy that all electronics in the playback chain should strive for neutrality, neither adding nor subtracting anything from the recording, no matter how "pleasing" such distortions may be. The Gryphon Apex is by nature a product for the fortunate few who can afford such a statement: a product for the connoisseurs who seek absolute purity in the reproduction of music. In short, Apex has been created for music lovers whose respect for the musicians, producers and mastering engineers inspires them to seek the truth lurking in the original recording.

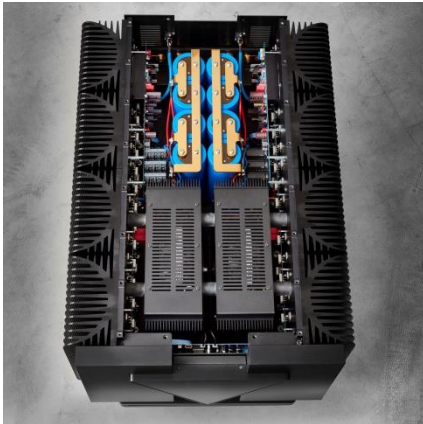

### **Power Is Everything**

In the world of High End audio amplification, this statement is literally true. With nearly 1700 Watts RMS into one Ohm (Mono), the Gryphon Apex is ready to master even the most challenging speaker loads. The Apex' output section uses very high-current bipolar output devices which have demonstrated extreme reliability in addition to unprecedented sonic performance. These transistors can be called upon to deliver very large peak power per channel without overload. The output transistors are locally decoupled with an array of ZN film capacitors.

Apex' driver section enjoys a separate, optimized power supply fed from individual windings on the custom-made toroidal transformers. Our unique and sophisticated mechanical design ensures optimal thermal tracking between drivers and output devices. This driver section features its own generous bank of the finest capacitors available for this application.

Apex' power supply also utilizes capacitors especially chosen for this design. Absolutely zero global feedback is employed and DC coupling utilizes DC servo circuitry. Internal wiring in the signal path is kept to an absolute minimum. Input wiring is Gryphon Vanta single crystal solid core silver/gold cable. Balanced inputs are provided exclusively. The new and proprietary Gryphon speaker terminals accept bare wire, spade lugs, banana connectors or any combination thereof.

Unique even in this lofty price range, the Gryphon Apex utilizes a completely independent transformer and linear power supply for display and control circuits, preventing digital noise generated by these circuits from contaminating the amplifier circuits.

### **Pure Class A**

True Class A operation has always been a Gryphon hallmark. Why? Because no other circuit topology can match the sonic perfection of pure Class A. Unfortunately, true Class A is even rarer today than when we introduced the legendary DM100 in 1991. Rising consumer awareness has forced some manufacturers to make outrageous, unsubstantiated claims of Class A power ratings that have more to do with marketing than technology. There are a growing number of so-called "new" Class A topologies based on automatic biasing which supposedly allow the amplifier to sense when the bias should increase to ensure constant Class A performance!

Put bluntly, you can't cheat physics. There are no engineering shortcuts when it comes to pure Class A, so we repeat with no apologies: TRUE, PURE CLASS A means heavy transformers, very large heatsinks, large quantities of expensive parts and costly assembly. While we appreciate and endorse every effort to conserve energy and preserve our global resources, our research into efforts to obtain Class A performance from class A/B topologies makes it clear that there simply is no substitute for the sheer magic of pure Class A.



### **Eternal Beauty**

Exquisitely wrought from the finest materials available, Apex' gorgeous, "Nordic Noir" chassis incorporates advanced constrained-layer-damping technologies to optimize resonance, while the specification of non-magnetic materials virtually eliminates electrical interference.

In every design and construction aspect, Apex is designed to be cherished and appreciated for a lifetime. It is an amplifier whose performance is unlikely to be surpassed. Ever. Experience Apex and we are sure you will agree. Please accept our cordial invitation to visit the showroom of your nearest authorized Gryphon dealer.



## Placement

Do not place your Gryphon component on or near any source of heat such as power amplifiers. Do not place any object on the top covering the ventilation holes or heat sinks of your Gryphon component. Do not place it in an enclosed space such as a cabinet, unless ample ventilation is provided. Failure to observe guidelines may result in overheating.

## AC voltage

Your Gryphon unit is especially made for the AC voltage of the country to which it has been shipped. If the voltage of your Gryphon has been changed, the warranty is void and the product may be unsafe or malfunction. Correct AC polarity contributes greatly to optimum performance. If you are not using a three-pin, non-reversible power plug, please experiment with the orientation of the plug for optimum performance.

## Care and Maintenance

Gryphon products are handcrafted by individuals who take great pride in the high level of fit and finish which we achieve. To maintain your Gryphon components in pristine condition, please follow these simple instructions. Metal surfaces may be cleaned with a damp cloth or dry microfiber cloth. Some products made for treatment of vinyl interiors in cars may be useful. Test the product on a non-visible surface before using any fluids. Acrylic surfaces should only be wiped with a very soft, dry cloth. Small scratches may be removed with acrylic surface polish. Fingerprints may be removed with a damp cloth or dry microfiber cloth. In order to avoid damage to your Gryphon's finish, do NOT use spirits or paper tissue.





## Choice of Cables

Gryphon's basic philosophy is one of sonic neutrality. We prefer to leave interpretation to the musicians and singers. Therefore, you should not need a cable with a particular "sound" of its own to balance or "equalize" your system. Unfortunately, in some circles, cables have become an acceptable equalizer in the High-End audio industry.

Take the advice of your authorized Gryphon dealer in selecting interconnects and loudspeaker cables for your Gryphon equipment and for that matter power cords as well. After all, we are listening to current "converted" into music!

Naturally, Gryphon's own range of interconnects, loudspeaker cables and power cords are used in the development of Gryphon products. Gryphon cables are designed for ultimate neutrality and resolution. They are extremely revealing and will allow the ultimate quality of your Gryphon system or any fine audio components to come through clearly and undiminished.

All Gryphon amplifiers are designed and manufactured with an extreme bandwidth and in some cases the wrong choice of speaker cable can become an issue and will create potential problems in the collaboration between the amplifier and the speakers, with the speaker cable as an interactive factor. Gryphon recommends that no speaker cable on a Gryphon amplifier should be with a coaxial design, active shielding or special boxes that will add-on different types of filtration. A speaker cable with a coaxial design or with active shielding will in most cases have a much lower bandwidth than the amplifier and therefore the amplifier will be met with a too high capacitive load and might cause oscillation of the amplifier. There is no need to actively add filtration on an analogue amplifier. It doesn't serve the final reproduction of the music any good.

Gryphon recommends using speaker cables with a low capacitance and a wide bandwidth in order to match the specs of the amplifier's bandwidth and output impedance. There is no need to add more "negative" filtration to the system as Gryphon is striving to have the finest level of tonal balance and neutrality. Choose your cables with the highest level of attention to the actual parameters of the cable design (e.g. cable geometry, capacitance, bandwidth, insulation, conductor material and connectors) and aim for low capacitance, low resistance and sonic neutrality.



## Unpacking and Setup

Please refer to separate Setup instruction document included with your unit. You can also find this document on our website.

## Burn-in and Warm-up

Your Gryphon unit has been thoroughly tested and burned-in before shipping; however, performance will continue to improve during the first 40 – 50 hours of normal use. After this period, optimum performance will be reached approximately 45 minutes after turn-on.

## Mains Switches

The two main ON/OFF switches on the Apex Power Amplifier are located on the rear panel.

## **SAFETY INSTRUCTIONS**

**Hazardous live AC power! Please find important safety instructions on p. 22**

## Apex Power Stereo and Mono Manual

### Indicators and touch buttons on Apex front panel:

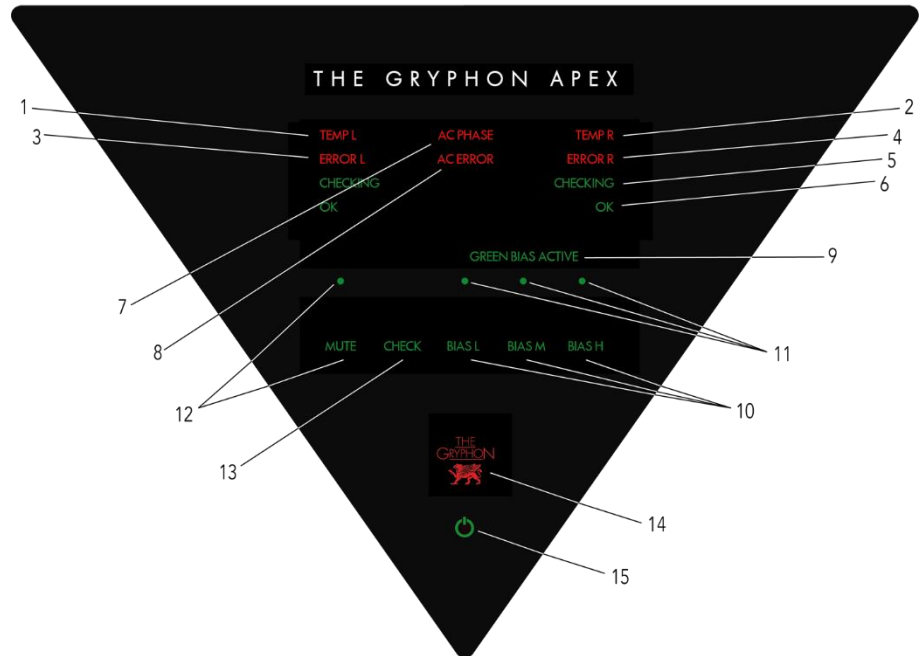

1. Temperature Error Left channel indicator
2. Temperature Error Right channel indicator
3. DC/HF Error Left amplifier channel indicator
4. DC/HF Error Right amplifier channel indicator
5. Checking all visual indicators when flashing green
6. Left/Right channel status OK indicator
7. AC Phase indicator
8. AC Error indicator.
9. Green Bias Active indicator
10. Capacitive touch buttons for amplifier BIAS Low, Medium, and High
11. Indicators for active BIAS Low, Medium, and High setting
12. Capacitive touch button and indicator for output MUTE, lit when in mute state
13. Capacitive touch button for indicator Check function
14. Gryphon Logo
15. Capacitive touch button for Apex ON/STB

## User Instructions



Apex in standby mode



### STANDBY MODE

#### ON/STB (Standby) touch button:

Make sure that the two AC mains switches on the rear panel are on before proceeding.

ON/STB symbol is red when the Apex is in standby mode.

#### Turn-ON procedure:

1. Turn ON source components; turntable, CD-players, etc.
2. Turn ON preamplifier.
3. Allow a few moments for components to stabilize.
4. Turn ON the Apex Power Amplifier(s).

#### Turn-OFF procedure:

1. Turn off the Apex Power Amplifier.
16. Turn off the rest of the system.

**ALWAYS TURN OFF OR MUTE THE APEX POWER AMPLIFIER(S) BEFORE CONNECTING OR DISCONNECTING ANY CABLES IN THE SYSTEM**

## Power ON



Apex ON, in BIAS H mode



### POWER ON MODE

After activating the ON/STB (Standby) touch button, the ON/STB symbol is now lit up in green colour and the Gryphon logo and all display indications will flash for app. 25 sec. before the amplifier is fully operational.

When the amplifier is ready, the Gryphon logo will stay on and left and right green “OK” indicators will be on for 5 sec. If Green Bias cable is connected and enabled; GREEN BIAS ACTIVE indicator will also be on for 5 sec.

If the two AC inlets are not connected to AC mains with same polarity; the AC PHASE indicator remains on. Please power down and correct the problem.

The Apex is a true dual mono construction, and we must strongly emphasize the importance of symmetrical AC power polarity for each channel.

Asymmetrical AC polarity will seriously degrade performance of the Apex Power Amplifier.

## Functions

### **MUTE:**

Use this function when changing speaker cables or interconnects without turning off the Apex Power Amplifier. MUTE is active when the green LED above the MUTE button is on.

### **CHECK:**

This function allows you to check that all indicators on the Apex front panel are operational. The green left - and right CHECKING indicators will flash together with all other indicators.

### **BIAS L:**

Use this mode to keep the circuitry in the amplifier ready for listening without initial warm-up - or for non-critical listening. Note: Disables Green Bias control.

### **BIAS M:**

This mode provides 100 Watts of pure class A, more than enough for normal listening conditions and speakers with normal sensitivity. The full power of the amplifier above 100 Watts will be available as Class A/B power.

### **BIAS H:**

100% Class A power for the ultimate performance.

### **About Bias Modes:**

The bias selectors determine the degree of Class A operation. In the BIAS H mode the Apex Stereo and Mono Power Amplifiers provides respectively 210 and 225 Watts of PURE CLASS A power into an 8 ohm load.

The bias adjustments do not change total output power, but only the Class A operation range.

With very efficient speakers, 210 Watts or 225 Watts of pure Class A might rightly be considered overkill. With BIAS M, efficient speakers will be driven in Class A most of, or all the time.

Naturally, lowering the Class A operation range reduces AC power consumption at idle.

When evaluating the sonic effect of the 3 bias adjustment modes, it must be taken into consideration that the Apex requires time to settle when bias is changed (approx. 45 min.).

## Rear Panel, Apex Stereo



### INPUT RIGHT / INPUT LEFT

Right and left stereo channel balanced XLR\* inputs.

### Right and left stereo channel loudspeaker outputs

Accepts bare wire, 4mm banana plugs, spade lugs (up to 17mm wide, min. 6,5mm between lugs) or any combination thereof. Positive (red) is hot, negative (black) is neutral.

**GREEN BIAS IN and PASS-THRU:** Please refer to the description in the chapter: "Green Bias". Also for switching the Apex between STB (Standby) and ON when connected to a Gryphon preamplifier via Green Bias control link.

**GROUND:** Binding post for chassis ground.

**12V LINK INPUT and PASS-THRU:** For switching the Apex between STB (Standby) and ON when connected to a unit with compatible link output.

**AC mains power switches:** NOTE: BOTH main switches must be switched ON before the amplifier will be operational.

**Mains input sockets:** Two IEC Appliance inlets C20 (for power cords with IEC C19 receptacle)

**Main fuse holders:** 100-120Vac: T16A / 250V      220-240Vac: T8A / 250V

\*) All Gryphon products follow the AES standard for balanced connections:

1. Ground
2. Positive
3. Negative

Gryphon recommends the use of dedicated balanced interconnect cables. Avoid the use of RCA-to-XLR adaptors as they will degrade system performance.

## Rear Panel, Apex Mono



### INPUT / INPUT PASS-THRU

Mono channel balanced XLR\* input and pass-thru.

### Mono channel loudspeaker outputs

The two pair of outputs are in parallel. Accepts bare wire, 4mm banana plugs, spade lugs (up to 17mm wide, min. 6,5mm between lugs) or any combination thereof. Both positive (red) is hot, both negative (black) is neutral.

**GREEN BIAS IN and PASS-THRU:** Please refer to the description in the chapter: "Green Bias". Also for switching the Apex between STB (Standby) and ON when connected to a Gryphon preamplifier via Green Bias control link.

**GROUND:** Binding post for chassis ground.

**12V LINK INPUT and PASS-THRU:** For switching the Apex between STB (Standby) and ON when connected to a unit with compatible link output.

**AC mains power switches:** NOTE: BOTH main switches must be switched ON before the amplifier will be operational.

**Mains input sockets:** Two IEC Appliance inlets C20 (for power cords with IEC C19 receptacle)

**Main fuse holders:** 100-120Vac: T16A / 250V      220-240Vac: T8A / 250V

\*) All Gryphon products follow the AES standard for balanced connections:

1. Ground
2. Positive
3. Negative

Gryphon recommends the use of dedicated balanced interconnect cables. Avoid the use of RCA-to-XLR adaptors as they will degrade system performance.



## Green Bias

If you are using a compatible Gryphon preamplifier, you may choose to connect the Green Bias control link to automatically change bias with reference to the current position of the preamplifier's volume control.

Please note that the green bias system and cable is not a part of the signal path and only has reference to the volume control position of the preamplifier.

The Apex Power Amplifier will change bias setting corresponding to preprogramed switching points from the preamplifiers volume control. It is possible to change these volume control switching points in your Gryphon preamplifier: Please refer to the manual for your preamplifier.

In order to enable Green Bias control; the Apex Power Amplifier must be set manually to BIAS M or BIAS H using the bias touch buttons on the front panel.

The Apex Power Amplifier will ignore Green Bias control if set to BIAS L manually on the front panel.

### **GREEN BIAS ACTIVE:**

The indicator will be on for 5 seconds if Green Bias cable is connected and changes state:

The Apex Power will change to Bias High if receiving "Bias High" command from the preamplifier.

It will change to Bias Medium if receiving "Bias Low" or "Bias Medium" commands from the preamplifier.

If you remove the green bias link cable between the Apex Power Amplifier and the Gryphon preamplifier, the Apex Power Amplifier will automatically revert to manual bias operation only.

In case you own a Gryphon preamplifier with only one green bias link output, and you have the Apex Mono Power Amplifiers set, do the following:

1. Connect the Green Bias cable included with your preamplifier from the Green Bias output on your preamplifier to Green Bias input on one of your Apex Mono Power Amplifiers.
2. Connect the Green Bias included with your Apex Mono Power Amplifiers from Green Bias pass-thru to Green Bias input on your second Mono Power Amplifier

## Features, Apex Stereo

- Pure Dual Mono configuration
- Zero global negative feedback
- 64 very high current bipolar output transistors
- 1.040.000 $\mu$ F (>1 Farad) capacitor bank
- Extremely low capacitance Class A J-FET input buffer
- Balanced dual differential class A input circuitry followed by a very fast symmetrical voltage amplifying Class A stage
- Fully regulated low noise power supply for all voltage amplifying stages
- DC servo coupling
- Frequency-independent damping factor
- Gryphon silver internal signal and power wiring
- Premium massive Zn foil capacitors used for local power supply decoupling, with a loss factor ten-times lower than of metallized PP-film capacitors.
- 4-layer up to 105  $\mu$ m copper printed circuit boards
- Two separate custom made 2000VA toroidal transformers
- Individual decoupled left/right transformer castings
- Separate linear power supply for both digital and analog circuits
- Soft start turn-on prevents triggering of fuses or circuit breakers in the home electrical system
- True balanced inputs with gold-plated Neutrik XLR input sockets
- Gryphon gold-plated custom-built binding posts
- AC polarity indicator
- 12V Link for remote power on and off
- Automatic Green Bias setting via Green Bias control link or manual Low/Mid/High bias
- Firmware upgradeable via USB stick
- Non-intrusive protection system
- Standby current consumption < 0.5W
- Designed and manufactured in Denmark

## Features, Apex Mono

Same features as Apex Stereo, except:

- 128 very high current bipolar output transistors (64 per Mono channel)
- 2,080,000 $\mu$ F (>2 Farad) capacitor bank (1,040,000 $\mu$ F per Mono channel)
- Four separate custom made 2000VA toroidal transformers (2 per Mono channel)
- One Gold-plated Neutrik XLR socket input signal pass-thru for each channel

## Specifications, Apex Stereo

- 2 x 210W @ 8 $\Omega$ , 2 x 420W @ 4 $\Omega$ , 2 x 800W @ 2 $\Omega$  and 2 x 1490W @ 1 $\Omega$  at 115V/230Vac
- Output impedance: 0.015 $\Omega$
- Bandwidth (-3dB): 0.3Hz to 330KHz
- Gain: +31,0dB
- Max. input level: 1,16Vrms
- Input Impedance, balanced (20-20000Hz): 20K $\Omega$
- Dimensions, WxHxD:59,3x37,1x88,6 cm, 202kg net.  
Please also see following page.
- Shipping dimensions:104 x 80 x 67 cm, 265kg

## Specifications, Apex Mono (one channel)

- 1 x 225W @ 8 $\Omega$ , 1 x 450W @ 4 $\Omega$ , 1 x 880W @ 2 $\Omega$  and 1 x 1690W @ 1 $\Omega$  at 115V/230Vac
- Output impedance: 0.010 $\Omega$
- Bandwidth (-3dB): 0.3Hz to 330KHz
- Gain: +31,0dB
- Max. input level: 1,20Vrms
- Input Impedance, balanced (20-20000Hz): 10K $\Omega$
- Dimensions, WxHxD::59,3x37,1x88,6 cm, 202kg net. - each amplifier channel.  
Please also see following page.
- Shipping dimensions for a pair: Two crates; each 104 x 80 x 67 cm, total 530kg

Note: Specifications can be changed without notice.

## Dimensions

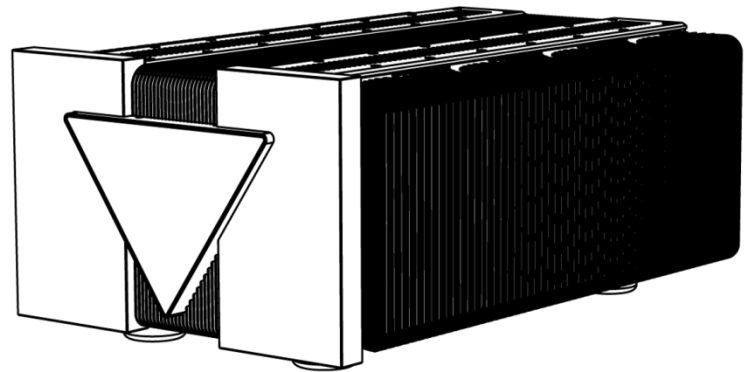
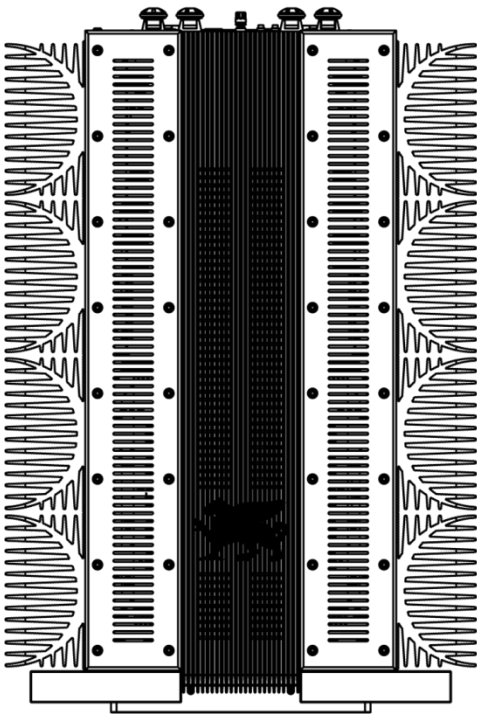
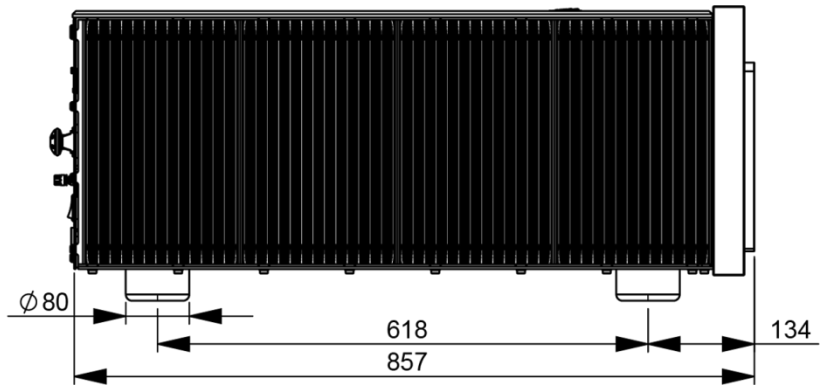
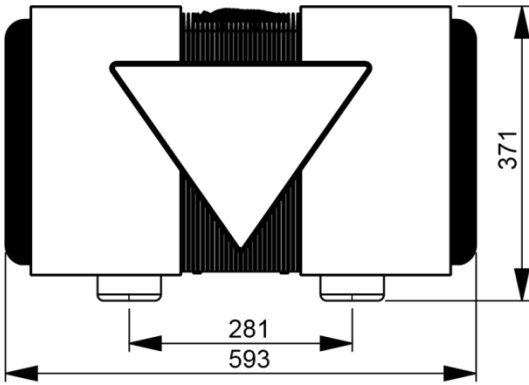

## Error Indication and Trouble Shooting



Error indicators on the Apex front panel

**TEMP L** and/or **TEMP R** indicator is on:

Left, right or both channels are overheating. When excessive heat is detected, the Apex will mute, and the amplifier will immediately go into standby mode.

Normal operation can resume when the temperature is within safe operating limits.

Secure good air circulation around the amplifier. Re-start amplifier after approx. 10 minutes when cooled down.

**ERROR L** and/or **ERROR R** indicator is on:

A DC/HF error has been detected in left, right or both channels. The amplifier is automatically muted and will immediately go into standby mode.

Please correct potential external reason for the error state - e.g. too high level or DC at the input of the power amplifier, shorted output, cause for oscillation, etc. Contact your Gryphon dealer for further assistance.

**AC PHASE** indicator is on constantly:

Polarity of the two AC power cords is asymmetrical. Turn OFF the amplifier and reverse one of them. (You may wish to experiment to find the optimum symmetrical configuration).

**AC ERROR** indicator is on constantly:

Available AC power is not corresponding to the amplifier's AC voltage range. The Apex amplifier is delivered from factory for either 110-120VAC or 220-240VAC, depending on delivery country.

## Further Trouble Shooting

### No red light in ON/STB touch button symbol:

- Check both power cord are OK and properly inserted.
- Check both on/off mains switches on rear panel are ON
- Check your domestic AC supply
- Check AC fuses on rear panel (Please disconnect power cords before removing fuses.)
- Check internal fuses behind lower front panel. Please see below.

### AC PHASE indicator is on even though polarity is OK:

- Check internal fuses behind lower front panel. Please see following pages.

### AC ERROR indicator is on even though AC power is OK:

- Check internal fuses behind lower front panel.. Please see following pages.

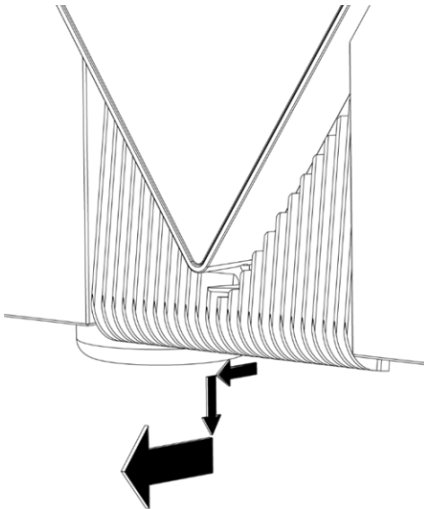

## Internal Fuses

There are several internal fuses in the Apex amplifier. Five of them are accessible from the Apex front when carefully removing the lower front panel. The lower front panel is attached with magnets. The panel is removed as shown on the illustration.

Note: The fuses behind the front panel are for control circuits only. None of these are related to the audio circuits in the Apex.



When the lower front panel is removed, the Apex front will look as shown above.

Please refer to the labels for correct fuse values.

Power OFF the Apex and remove both power cords before any fuse are replaced!

Never rely on visual check of fuses. Always test continuity with a multimeter or similar.

Blown fuses must be replaced with same fuse values and types only.

Do not replace these fuses without consulting your authorized Gryphon dealer or distributor.

F1-2: T63mA / 250Vac

F3: T1A / 250Vac

F4-5: T315mA / 250Vac

Recommended F1-5 fuse manufacturer and type: SCHURTER FST, 5x20mm.

All fuses are Time lag (slow blow) types.

USB port: For firmware programming only! For authorized service technicians only!

## Warranty & Support

The Gryphon Apex Power Amplifiers is warranted against failures arising through faulty workmanship and materials for a period of 5 years from date of purchase. The warranty is not transferable.

**This warranty is only valid in the country where the product was purchased.**

All claims under this warranty must be made to the distributor in the buyers' country by returning the unit securely packed in the original box with all accessories, postage/freight prepaid and insured. The unit will be repaired or replaced at no charge for parts and labor.

**This warranty will be void if the serial number of the unit has been defaced or removed.**

No user serviceable parts inside. **This warranty will be void if the unit has been repaired or modified by non-authorized Gryphon dealers or distributors.** Optional modules must be installed by authorized dealers and distributors only.

This warranty does not cover damage due to misuse, accident or neglect.

**This warranty is not valid if the operation voltage of the product has been changed.**

The distributor or manufacturer, Gryphon Audio Designs, Denmark, retains the exclusive right to make such judgement on the basis of inspection.

The retailer, distributor or manufacturer of the Gryphon shall not be liable for consequential damage arising from the use, misuse or failure of this product, including injuries to persons or property.

Please do not directly contact Gryphon for repair, warranty issues or technical questions. Our local representatives are competent and happy to help you.

**To qualify for this warranty; the enclosed warranty registration card must be filled out and returned to Gryphon Audio Designs within 30 days of purchase.**

Alternatively, you may wish to register online at [www.gryphon-audio.com](http://www.gryphon-audio.com)

*To confirm your warranty registration, you will receive a little Gryphon token to welcome you to the family of Gryphon owners.*

### Notes

Gryphon Model:	
Serial No.:	
Date of Purchase:	
Dealer:	
Country:	



## IMPORTANT SAFETY INSTRUCTIONS

Read these instructions.

Keep these instructions.

Heed all warnings.

Follow all instructions.

Do not use this apparatus near water.

Clean only with dry cloth.

Do not block any ventilation openings. Install in accordance with the manufacturer's instructions.

Do not install near any heat sources such as radiators, heat registers, stoves, or other apparatus (including amplifiers) that produce heat.

Do not defeat the safety purpose of the polarized or grounding-type plug.

US power plugs (NEMA5-15) only: A polarized plug has two blades with one wider than the other. A grounding type plug has two blades and a third grounding prong. The wide blade or the third prong is provided for your safety. If the provided plug does not fit into your outlet, consult an electrician for replacement of the obsolete outlet.

Protect the power cord from being walked on or pinched particularly at plugs, convenience receptacles, and the point where they exit from the apparatus.

Only use attachments/accessories specified by the manufacturer.

Unplug this apparatus during lightning storms or when unused for long periods of time.

Refer all servicing to qualified service personnel. Servicing is required when the apparatus has been damaged in any way, liquid has been spilled or objects have fallen into the apparatus, the apparatus has been exposed to rain or moisture, does not operate normally, or has been dropped

Do not open the equipment to reduce the risk of electrical shock. Refer all disassembling to qualified service personnel.

**WARNING:** To reduce the risk of fire or electric shock, this apparatus should not be exposed to rain or moisture and objects filled with liquids, such as vases, should not be placed on this apparatus.

To completely disconnect this equipment from the mains, disconnect the power supply cord plugs from the receptacle.

The mains plug of the power supply cords shall remain readily operable.

No naked flame sources, such as lighted candles, should be placed on the apparatus.

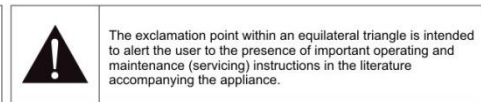
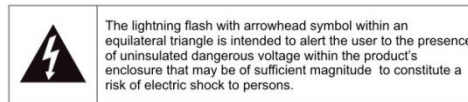

## Notes

---

---

---

---

---

---

---

---

---

---

---

---

---

---

---

---

---

---

---

---

---

---

---

---

---

---

---

---

---

---